

鋁手輪



TG-160

Aluminum handwheel



商品介紹 Product description

- 材質：手輪-鋁合金、把手-電木、摺疊結構-鐵
- 表面處理：手輪-黑色烤漆、銀色烤漆
把手-黑色、摺疊結構-染黑

- Material: Handwheel - aluminum alloy, Handle - bakelite, Folding structure - iron
- Finish: Handwheel - black paint, silver paint
Handle - Black, Folding Structure - Dyed Black

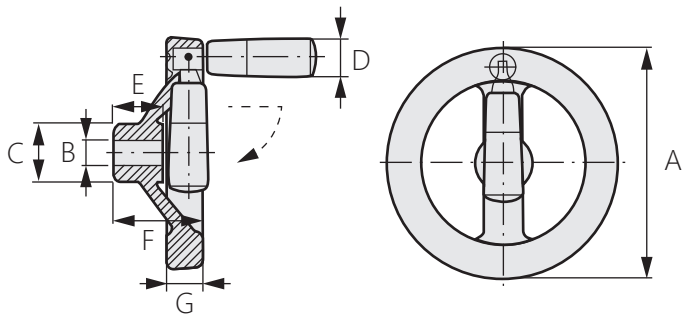

商品型號		A	B	C	D	E	F	G
黑色	銀色							
TG-160-1-BK	TG-160-1-SR	125	B12	31	23	26	51	26
TG-160-2-BK	TG-160-2-SR	140	B14	32		31	53	20
TG-160-3-BK	TG-160-3-SR	160	B14	35	26	33	57	23.5
TG-160-4-BK	TG-160-4-SR	200	B18	42		24	52.5	25
TG-160-5-BK	TG-160-5-SR	250	B22	48		28	61	26.5