

PP輪



JZ-303

PP wheels

商品介紹 Product description

- 1.一體拉伸成型支架。
- 2.雙波盤結構。
- 3.全覆式防塵蓋。

- 材質：單軸承塑芯PP輪
- 用途：家俱、輕流物流台車、一般手推車、輕型機械設備

1. One-piece stretch forming bracket.
2. Double wave disc structure.
3. Full-coverage dust cover.

- Material: Single bearing plastic core PP wheel
- Uses: Furniture, light logistics trolleys, general trolleys, light machinery and equipment.



[JZ-303-1S]



[JZ-303-1R]



[JZ-303-1H]



[JZ-303-1G]



[JZ-303-1D]



[JZ-303-2S]



[JZ-303-2H]



[JZ-303-2G]



[JZ-303-2D]



[JZ-303-3S]



[JZ-303-3H]



[JZ-303-3G]



[JZ-303-3D]

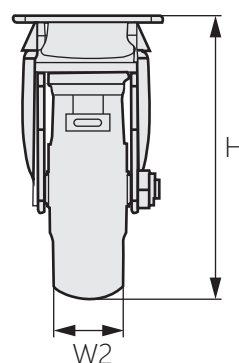
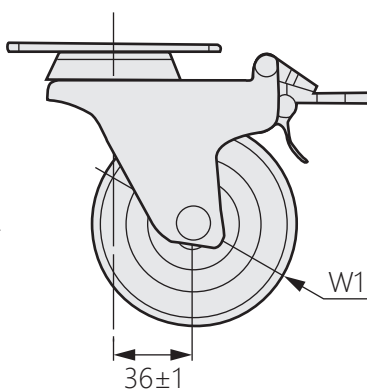
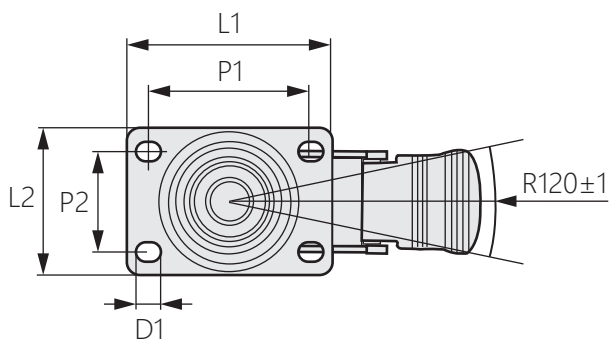

商品型號	輪子	輪徑	輪寬	安裝高度	底板尺寸	孔距	孔徑	荷重 (KG)
JZ-303-1-1_	PP	63	25	92	95*66	75*45	8.5	75
JZ-303-1-2_		75		108				120
JZ-303-1-3_		100		130				130
JZ-303-1-4_		125		159				150
JZ-303-1-5_		150		181				165

JZ-303-1系列可選配R固定/S活動/H煞車/G鐵煞/K疊煞/D邊煞

商品型號	輪子	輪徑	輪寬	安裝高度	牙桿尺寸	荷重 (KG)
JZ-303-2-1_	PP	63	32	92	M12*30	75
JZ-303-2-2_		75		108		120
JZ-303-2-3_		100		130		130
JZ-303-2-4_		125		159		150
JZ-303-2-5_		150		181		165

JZ-303-2系列可選配S活動/H煞車/G鐵煞/K疊煞/D邊煞

商品型號	輪子	輪徑	輪寬	安裝高度	孔頂尺寸	荷重 (KG)
JZ-303-3-1_	PP	63	32	92	Ø13	75
JZ-303-3-2_		75		108		120
JZ-303-3-3_		100		130		130
JZ-303-3-4_		125		159		150
JZ-303-3-5_		150		181		165

JZ-303-3系列可選配S活動/H煞車/G鐵煞/K疊煞/D邊煞