

不鏽鋼調整型夾鉗(垂直型)

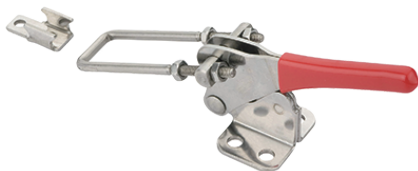

DK-152

Stainless steel adjustable series clamp
(Vertical type)



安裝示意圖

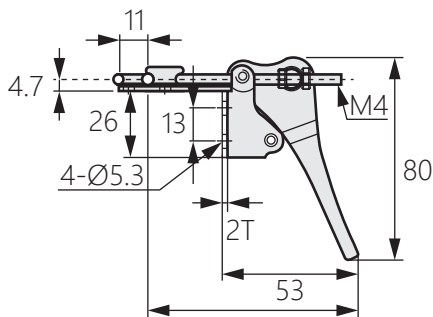

可調整83-100

商品介紹 Product description

- 1.可調節型全金屬夾鉗，適用於工作負載大以需要大幅度調整間距的情況。
- 2.體積小，安裝方便。
- 3.最大夾持力：225公斤。

- 材質：不鏽鋼SUS304
- 用途：電箱電櫃、機械設備等

1. Adjustable row all-metal clamps,suitable for situations where the working load is large and the spacing needs to be greatly adjusted.
2. Small size,easy to install.
3. Maximum clamping force : 225 kg.

- Material: Stainless steel SUS304
- Uses: Electric box,electrical cabinet,mechanical equipment,etc.

